

little tikes.

4339

624339100 - 5/14

www.littletikes.com

www.littletikes.co.uk

www.littletikes.nl

www.littletikes.pl

## ENGLISH

### EASY STORE™ BASKETBALL

Ages 3 years & up

Please save sales receipt for proof of purchase.

#### WARNING:

##### ADULT ASSEMBLY REQUIRED.

- Warning! Not suitable for children under 3 years due to long cords - strangulation hazard.
- Place this product on a flat surface for stability.
- To prevent tipping and potential injury, do not attempt to stand the basketball set up without first filling the base with 90 lbs. (40 Kg) of sand (not included). The unit may fall over without weight in the base.
- Illus. 18 - 23 Follow net attachment illustrations 18 - 23 exactly! Always make sure net is attached completely. Make sure the label on the net is along the bottom edge (Illus. 18).
- Protect your eyes. Always wear safety glasses when using a hammer.

#### ASSEMBLY HINT

Illus. 3 - 4 Fill base with 90 lbs. (40 Kg) of sand using both fill holes. Turn base upright and tap to pack sand into base.

Illus. 5 If plug in base is tight, use pliers to remove or install.

#### IF BASKETBALL NEEDS AIR:

- Use a standard athletic inflating needle available at most sporting goods stores.
- Moisten needle to insert into plug.
- A bicycle pump is recommended to pump air into ball.
- Inflate ball to approximately 6" (15 cm) in diameter.

#### CONSUMER SERVICE

##### TOLL-FREE NUMBER:

##### United States:

www.littletikes.com

1-800-321-0183 Monday - Friday

The Little Tikes Company

2180 Barlow Road

Hudson, OH 44236

E-mail: littletikes.cares@littletikescare.com

##### United Kingdom:

www.littletikes.co.uk

Little Tikes

MGA Entertainment (UK) Ltd

50 Presley Way

Crownhill

Milton Keynes MK8 0ES

Adult assembly required / Le montage devra être effectué par un adulte /  
Debe ser armado por un adulto

Tools required (not included):  
Outils Requis (ne sont pas inclus):  
Herramientas Requeridas (no se incluye):

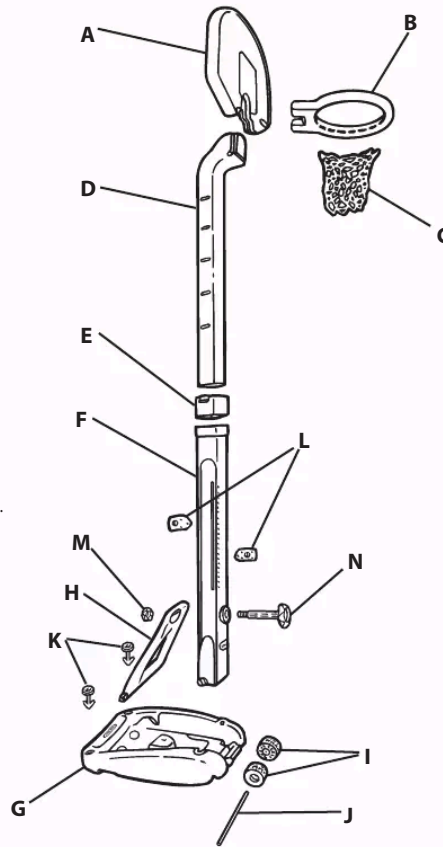

- Ball may have deflated during shipping. See instructions for how to inflate.
- Le ballon peut s'être dégonfler pendant le transport. Voir instructions pour le regonfler.
- Es posible que la pelota se haya desinflado durante el transporte. Lea las instrucciones para inflarla.
- Der Ball kann beim Transport Luft verloren haben. Er kann den Anleitungen gemäß wieder aufgepumpt werden.
- La palla durante il trasporto potrebbe sgonfiarsi. Vedere le istruzioni per gonfiarla.
- Het is mogelijk dat de bal tijdens transport is leeggelopen. Zie handleiding om de bal weer op te pompen.
- Luftrycket i bollen har kanske minskat under transporten. Läs handledningen innan du pumpar upp den.
- La palla durante il trasporto potrebbe sgonfiarsi. Vedere le istruzioni per gonfiarla.
- Het is mogelijk dat de bal tijdens transport is leeggelopen. Zie handleiding om de bal weer op te pompen.
- Luftrycket i bollen har kanske minskat under transporten. Läs handledningen innan du pumpar upp den.
- Ballen kan ha mistet luft under transport og lagring. Se veiledningen om hvordan fylle luft i ballen.
- A bola pode murchar durante o transporte. Siga as instruções para enchê-la corretamente.
- Pallo on saattanut toimituksen aikana tihjentyä. Katso täyttö-ohjeet.
- Η μπάλα μπορεί να έχει ξεφουσκώσει κατά τη μεταφορά. Δείτε τις οδηγίες πώς να τη φουσκώσετε.

Outside U.S.A and Canada: Contact place of purchase for warranty service. This warranty gives you specific legal rights, and you may also have other rights, which vary from country/state to country/state. Some countries/states do not allow the exclusion or limitation of incidental or consequential damages, so the above limitation or exclusion may not apply to you.

Please keep this manual as it contains important information.

little tikes.

Visit our website at  
www.littletikes.com  
to register your product online and  
to enter our sweepstakes.  
(No purchase necessary)

## FRANÇAIS

1

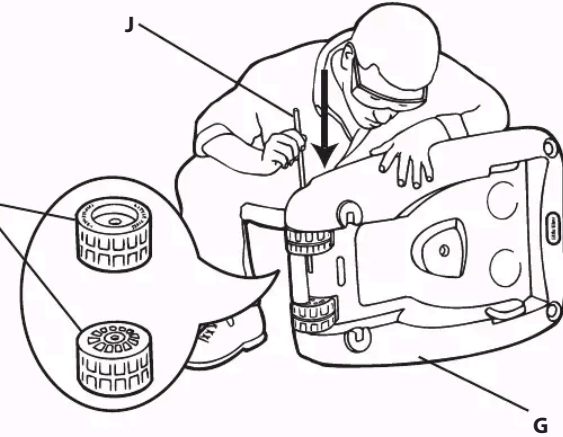

2

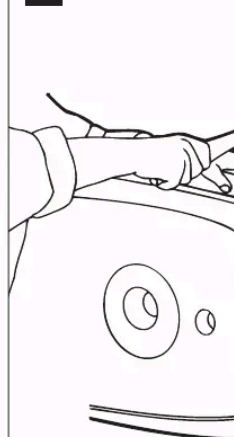

3

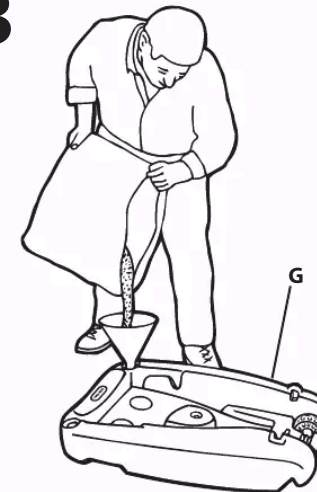

4



6



**IMPORTANT:**  
For easier assembly and breakaway rim operation, lubricate these areas with liquid dish soap. Make sure rim is "top side" up before assembly.

**IMPORTANT:**

soap

7



- Illus. 18 - 23 Suivez avec exactitude les illustrations 18 - 23 pour l'attachement du filet ! Toujours s'assurer que le filet est complètement attaché. S'assurer que l'étiquette se situe le long du bord inférieur (Illus. 18).
- Protéger ses yeux. Toujours porter des lunettes de sécurité lors de l'utilisation d'un marteau.

#### INSTRUCTION DE MONTAGE

Illus. 3 - 4 Remplissez la base avec 40 kg de sable en utilisant les deux trous de remplissage. Tournez la base à la verticale pour tasser le sable dans la base.

Illus. 5 Si le bouchon de la base est serré, utilisez des pinces pour l'enlever ou l'installer.

#### POUR GONFLER LE BALLON :

- Utiliser une aiguille de gonflage standard disponible dans tous les magasins de sport.

Bucks, UK  
E-mail: [Info.LittleTikes@mgae.com](mailto:Info.LittleTikes@mgae.com)

Printed in Poland. D.R. ©2014 The Little Tikes Company

U.S. Pat. No. 5,893,809

© The Little Tikes Company, an MGA Entertainment company. LITTLE TIKES® is a trademark of Little Tikes in the U.S. and other countries. All logos, names, characters, likenesses, images, slogans, and packaging appearance are the property of Little Tikes. Please keep this address and packaging for reference since it contains important information. Contents, including specifications and colors, may vary from photos depicted on package. Instructions included. Please remove all packaging including tags, ties & tacking stitches before giving this product to a child.

#### LIMITED WARRANTY

The Little Tikes Company makes fun, high quality toys. We warrant to the original purchaser that this product is free of defects in materials or workmanship for one year \* from the date of purchase (dated sales receipt is required for proof of purchase). At the sole election of The Little Tikes Company, the only remedies available under this warranty will be the replacement of the defective part or replacement of the product. This warranty is valid only if the product has been assembled and maintained per the instructions. This warranty does not cover abuse, accident, cosmetic issues such as fading or scratches from normal wear, or any other cause not arising from defects in material and workmanship. \*The warranty period is three (3) months for daycare or commercial purchasers. **U.S.A and Canada:** For warranty service or replacement part information, please visit our website at [www.littletikes.com](http://www.littletikes.com), call 1-800-321-0183 or write to: Consumer Service, The Little Tikes Company, 2180 Barlow Road, Hudson OH 44236, U.S.A. Some replacement parts may be available for purchase after warranty expires—contact us for details.

#### BASKETBALL

Age 3 ans et plus

Prière de conserver le reçu comme preuve d'achat.



### ATTENTION: UN ADULTE DOIT EFFECTUER L'ASSEMBLAGE.

- Attention! Ne convient pas aux enfants de moins de 3 ans en raison d'une longue corde - le risque de suffocation.
- Placer le basket ball sur une surface plate pour un maximum de stabilité.
- Pour éviter tout renversement ou blessure potentielle, ne pas tenter de positionner l'ensemble de Basketball sans d'abord remplir la base avec 40 kg de sable (non compris). L'unité pourrait tomber sans le poids dans la base.

2. Humidifier l'aiguille avant de l'introduire dans le ballon.
3. Une pompe de bicyclette est recommandée pour gonfler le ballon.
4. Gonfler le ballon jusqu'à ce qu'il atteigne 15 cm de diamètre.

#### SERVICE CONSOMMATEURS

[www.littletikes.com](http://www.littletikes.com)

Little Tikes

MGA Entertainment Netherlands BV

[klantenservice@mgae.com](mailto:klantenservice@mgae.com)

Fax : +31 (0)20 659 8034



Imprimé en Pologne.

© The Little Tikes Company, et MGA Entertainment company. LITTLE TIKES® est une marque de commerce de Little Tikes aux États-Unis et dans d'autres pays. Tous les logos, noms, caractères, similitudes, images, slogans et apparence d'emballage sont la propriété de Little Tikes. Merci de conserver cette adresse et cet emballage car ils contiennent des informations importantes. Le contenu, y compris les spécifications et les couleurs, peut varier des illustrations de l'emballage. Instructions incluses. Merci d'enlever l'emballage, y compris les étiquettes, liens et fils cousus, avant de donner ce jouet à un enfant.

Pour faciliter le montage du cercle de panier, graisser ces endroits avec du savon liquide. S'assurer avant le montage que le cercle est positionné avec la "partie supérieure" vers le haut.

#### IMPORTANTE:

Para facilitar el ensamblado y funcionamiento del aro plegable, lubrique estas áreas con detergente líquido para vajilla. Asegúrese de que la "parte superior" del aro está hacia arriba antes de ensamblado.

savon  
detergente

